



Micro Commercial Components

Micro Commercial Components
20736 Marilla Street Chatsworth
CA 91311
Phone: (818) 701-4933
Fax: (818) 701-4939

MMBT2222A

NPN General Purpose Amplifier

Features

- Surface Mount SOT-23 Package
- Capable of 350mWatts of Power Dissipation, $I_C=600mA$
- Operating Junction Temperature: $-55^{\circ}C$ to $+150^{\circ}C$
- Storage Temperature: $-55^{\circ}C$ to $+150^{\circ}C$
- Case Material: Molded Plastic. UL Flammability Classification Rating 94-0 and MSL Rating 1
- Marking: 1P

Electrical Characteristics @ 25°C Unless Otherwise Specified

Symbol	Parameter	Min	Max	Units
OFF CHARACTERISTICS				
$V_{(BR)CEO}$	Collector-Emitter Breakdown Voltage* ($I_C=10mA$, $I_B=0$)	40		Vdc
$V_{(BR)CBO}$	Collector-Base Breakdown Voltage ($I_C=10\mu A$, $I_E=0$)	75		Vdc
$V_{(BR)EBO}$	Emitter-Base Breakdown Voltage ($I_E=10\mu A$, $I_C=0$)	6.0		Vdc
I_{BL}	Base Cutoff Current ($V_{CE}=60Vdc$, $V_{BE}=3.0Vdc$)		20	nAdc
I_{CEX}	Collector Cutoff Current ($V_{CE}=60Vdc$, $V_{BE}=3.0Vdc$)		10	nAdc

ON CHARACTERISTICS

h_{FE}	DC Current Gain* ($I_C=0.1mA$, $V_{CE}=10Vdc$)	35		
		50		
		75		300
		100		300
		50		300
$V_{CE(sat)}$	Collector-Emitter Saturation Voltage ($I_C=150mA$, $I_B=15mA$)	0.3		Vdc
		1.0		Vdc
$V_{BE(sat)}$	Base-Emitter Saturation Voltage ($I_C=150mA$, $I_B=15mA$)	0.6		Vdc
		1.2		Vdc
		2.0		Vdc

SMALL-SIGNAL CHARACTERISTICS

f_T	Current Gain-Bandwidth Product ($I_C=20mA$, $V_{CE}=20Vdc$, $f=100MHz$)	300		MHz
C_{obo}	Output Capacitance ($V_{CB}=10Vdc$, $I_E=0$, $f=1.0MHz$)		8.0	pF
C_{ibo}	Input Capacitance ($V_{BE}=0.5Vdc$, $I_C=0$, $f=1.0MHz$)		25	pF
NF	Noise Figure ($I_C=100\mu A$, $V_{CE}=10Vdc$, $R_S=1.0k\Omega$, $f=1.0kHz$)		4.0	dB

SWITCHING CHARACTERISTICS

t_d	Delay Time	($V_{CC}=30Vdc$, $V_{BE}=0.5Vdc$)	10	ns
t_r	Rise Time	($I_C=150mA$, $I_B=15mA$)	25	ns
t_s	Storage Time	($V_{CC}=30Vdc$, $I_C=150mA$)	225	ns
t_f	Fall Time	($I_{B1}=I_{B2}=15mA$)	60	ns

*Pulse Width $\leq 300\mu s$, Duty Cycle $\leq 2.0\%$

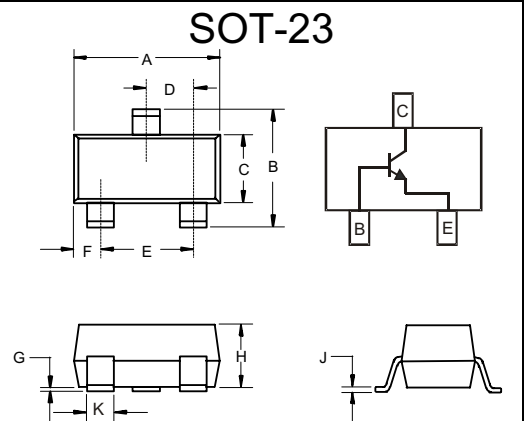

DIM	INCHES		MM		NOTE
	MIN	MAX	MIN	MAX	
A	.110	.120	2.80	3.04	
B	.083	.098	2.10	2.64	
C	.047	.055	1.20	1.40	
D	.035	.041	.89	1.03	
E	.070	.081	1.78	2.05	
F	.018	.024	.45	.60	
G	.0005	.0039	.013	.100	
H	.035	.044	.89	1.12	
J	.003	.007	.085	.180	
K	.015	.020	.37	.51	

Suggested Solder Pad Layout

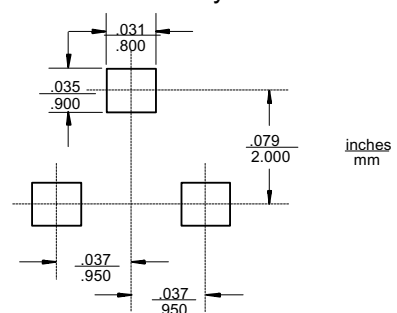

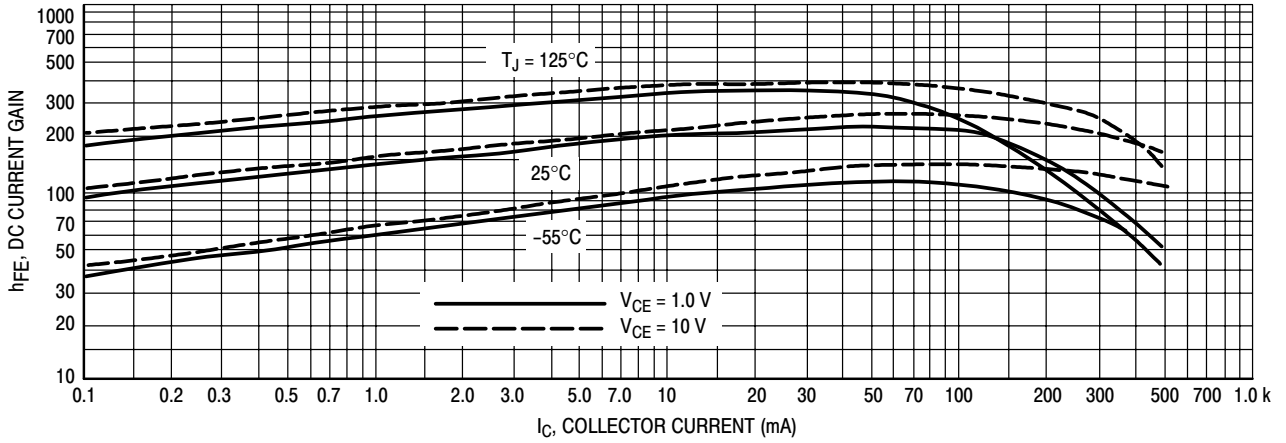

Figure 1. DC Current Gain

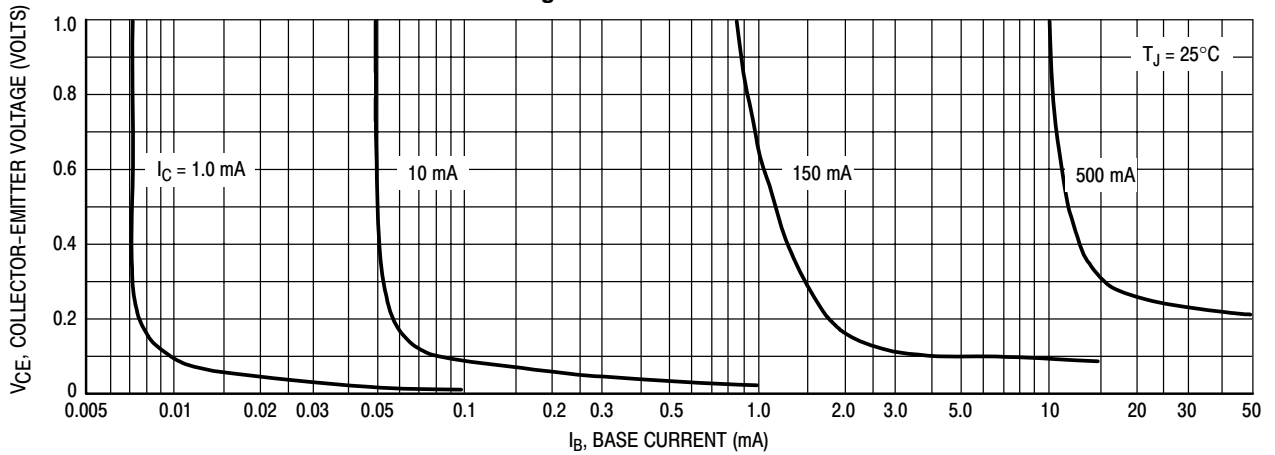

Figure 2. Collector Saturation Region

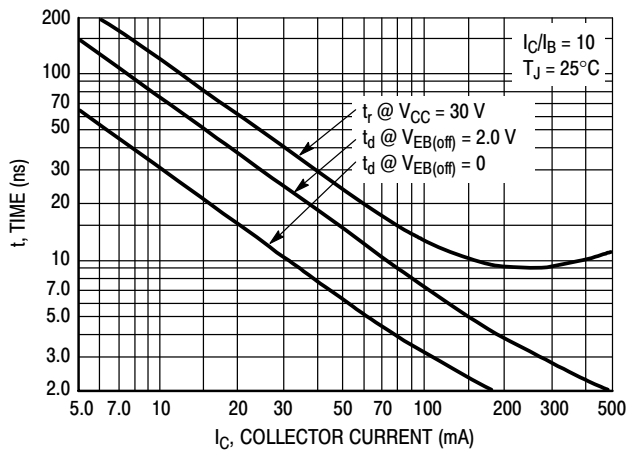

Figure 3. Turn-On Time

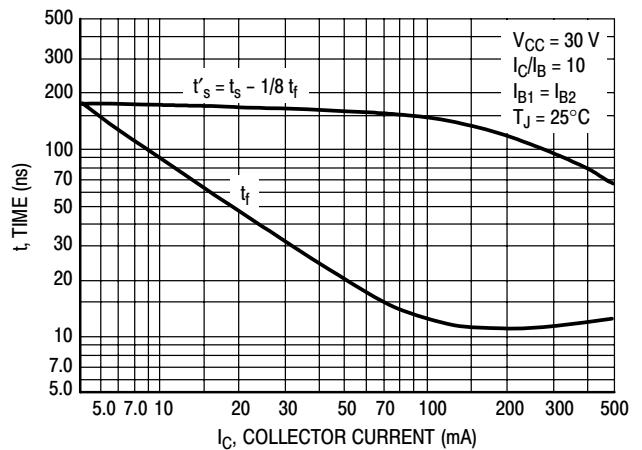

Figure 4. Turn-Off Time

MMBT2222A

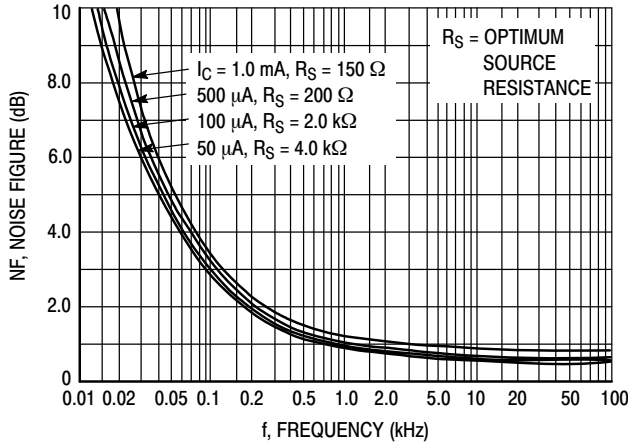

Figure 5. Frequency Effects

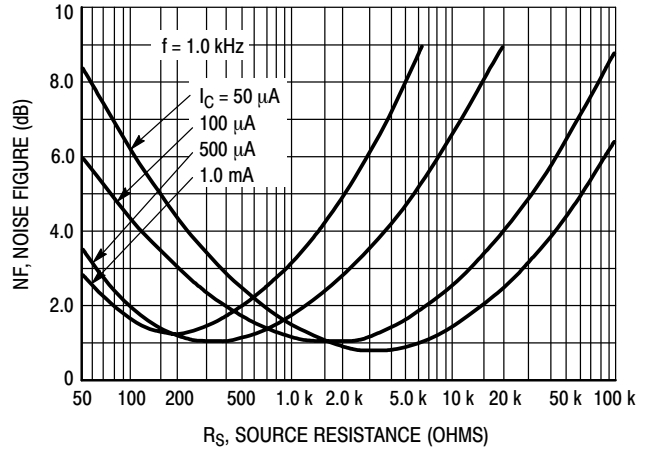

Figure 6. Source Resistance Effects

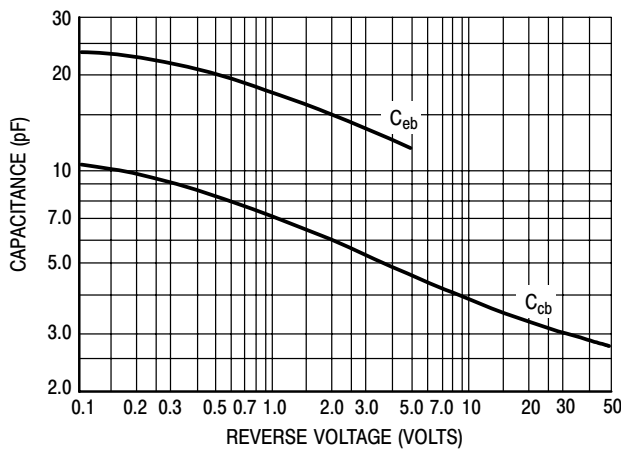

Figure 7. Capacitances

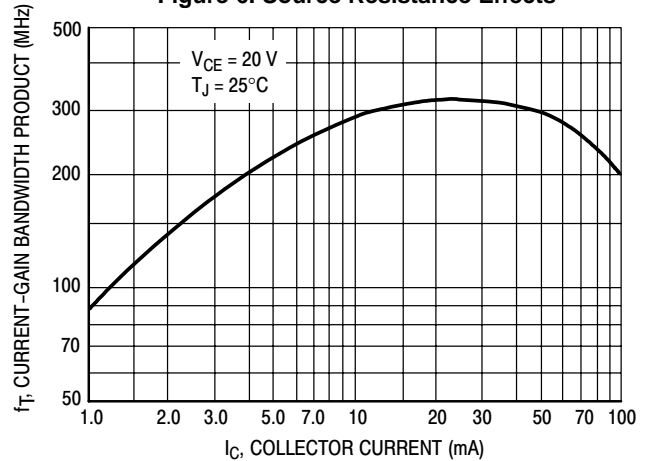

Figure 8. Current-Gain Bandwidth Product

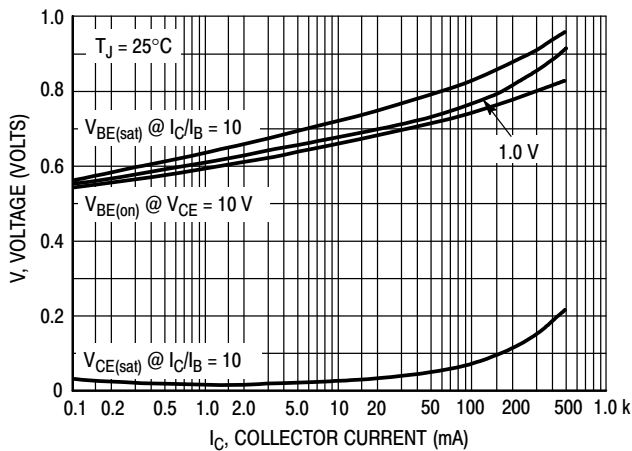

Figure 9. "On" Voltages

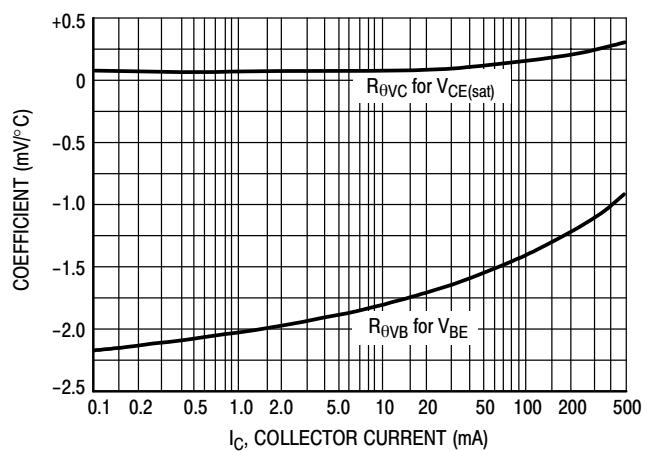

Figure 10. Temperature Coefficients



Micro Commercial Components

Ordering Information

Device	Packing
(Part Number)-TP	Tape&Reel;3Kpcs/Reel

IMPORTANT NOTICE

Micro Commercial Components Corp. reserves the right to make changes without further notice to any product herein to make corrections, modifications, enhancements, improvements, or other changes. *Micro Commercial Components Corp.* does not assume any liability arising out of the application or use of any product described herein; neither does it convey any license under its patent rights, nor the rights of others. The user of products in such applications shall assume all risks of such use and will agree to hold *Micro Commercial Components Corp.* and all the companies whose products are represented on our website, harmless against all damages.

APPLICATIONS DISCLAIMER

Products offer by *Micro Commercial Components Corp.* are not intended for use in Medical, Aerospace or Military Applications.